

BẢNG KÊ NGUYÊN VẬT LIỆU

Số TT	Tên phụ kiện	Tải trọng phá hoại	Số lượng	Vật liệu chế tạo
1	Bu lông U	240	01	Hiện hữu
2	Mắt nối	240	01	Hiện hữu
3	Khánh	240	02	Hiện hữu
4	Vòng treo đầu tròn	120	02	Hiện hữu
5	Mô phỏng		02	Thép mạ kẽm - Thay mới
6	Cách điện U120BP	120	2x15	Gốm/thủy tinh - Thay mới
7	Vòng đẳng thế		02	Thép mạ kẽm - Thay mới
8	Mắt nối	120	02	Hiện hữu
9	Mắt nối đơn	240	02	Hiện hữu
10	Khánh	240	01	Hiện hữu
11	Mắt nối chuyển hướng	120	02	Hiện hữu
12	Đệm dây		02	Hiện hữu
13	Khóa đỡ dây dẫn	120	02	Hiện hữu

Ghi chú:

- Tất cả các kích thước tính bằng đơn vị mm
- Tải trọng chuỗi cách điện là 2x120kN
- Số lượng bát: 15 bát loại U120BP đang tính toán với dòng dò bát là 440mm/kV
- Chuỗi cách điện sử dụng cho dây dẫn 2xACSR 400/51

Dòng dò quy định (mm/kV)	Ký hiệu cách điện	Tổng chiều dài đường dò (mm)
25	DDD.2-120	6600

CÔNG TY TRUYỀN TẢI ĐIỆN LỰC TRUYỀN TẢI ĐIỆN NINH BÌNH		ĐƯỜNG DÂY 220KV THÁI BÌNH - TIỀN HẢI - TRỰC NINH	
P.Giám đốc	Đỗ Đình Dũng	CHUỖI ĐỖ KÉP DÂY DẶN: DDD.2.120	
Kiểm tra	Lê Xuân Tử	BVTC	2024
Người vẽ	Đỗ Xuân Điện		

THIS DRAWING IS THE PROPERTY OF "TAG CORPORATION" AND SHOULD NOT BE COPIED OR REPRODUCED WITHOUT PROPER AUTHORIZATION.

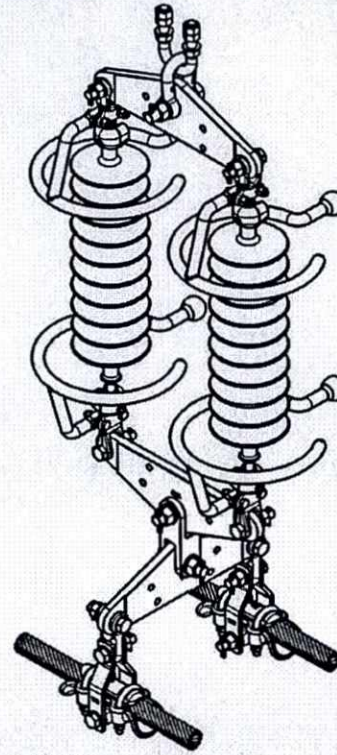
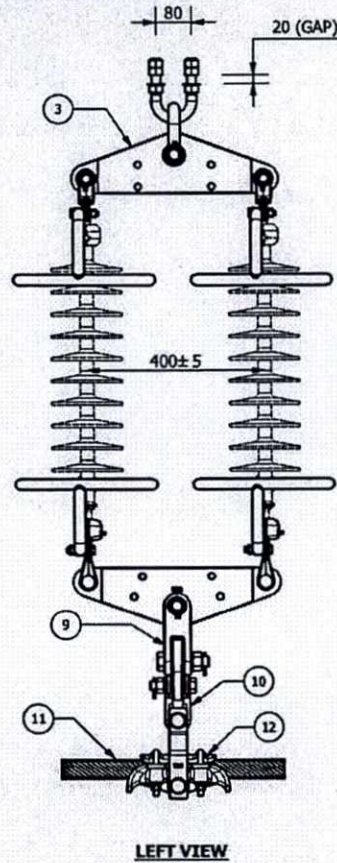
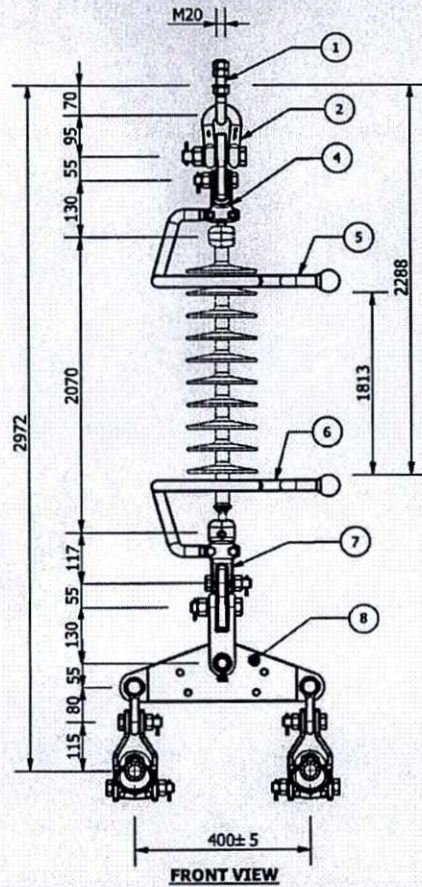

ISO VIEW

ITEM CODE F 0 0 2 3 8 0 0 3

- TECHNICAL DATA**
1. ASSEMBLY MINIMUM ULTIMATE TENSILE STRENGTH - 240 kN.
  2. BALL & SOCKET DESIGNATION - 16MM AS PER IEC - 120.
  3. BALL & SOCKET LOCKING BY R-CLIP AS PER IEC-372.  
MADE OF STAINLESS STEEL.
  4. FERROUS PARTS - HOT DIP GALVANIZED AS PER ISO 1461.
  5. GENERAL TOLERANCE UNLESS OTHERWISE SPECIFIED IS ±3%.
  6. TOLERANCE ON LENGTH OF HARDWARE IS ±2%.
  7. HARDWARE SUITABLE FOR ACSR/Mz 400/51 (Ø27.6) CONDUCTOR.
  8. COMPOSITE INSULATOR NOT IN TAG'S SCOPE OF SUPPLY.
  9. WEIGHT OF THE STRING - 73.33 kg (APPROX).
  10. WEIGHTS INDICATIVE ONLY.
  11. ALL DIMENSIONS ARE IN mm.
  12. SHORT CIRCUIT CURRENT CAPACITY : 41.1 kA / 1 Sec (Maximum).

REF. DRG.NO: DDD.2.120

Project Name: Package 03: Supply and transport of insulators and fittings, OPGW cable and accessories for 220kV Thai Binh - Tien Hai - Truc Ninh double circuit transmission line

P.O.Ref.No.: -

Purchaser: M/s. NPMB

Contractor: M/s.

Manufacturer: TAG CORPORATION, CHENNAI.

2 08.12.2016 ITEM CODE, PRODCT CODE, COMP.CODE ADDED

1 18.10.2016 (ITEM NO : 5 & 6) NEW ARCING HORNS ADDED

REV	DATE	DESCRIPTION	APP. BY
REVISION HISTORY			

ITEM NAME:  
**220 kV DOUBLE SUSPENSION 'I' STRING FOR TWIN ACSR/Mz Ø27.6 CONDUCTOR**

DRG.NO: TAG/E/DSI/T2/LJ/A

DATE: 19.07.2016

**TAG CORPORATION**  
CHROME PET, CHENNAI - 600 044  
EXPORT TAMILNADU, INDIA.

DRAWN BY: P.R.B  
CKD. BY: R.M  
APP. BY: V.T.C  
SCALE: 1:11

SL.NO	DESCRIPTION	MATERIAL	DRG. NO	COMP. CODE	ITEM CODE	UTS (KN)	QTY (NOS.)
12	TRUNNION SUSPENSION CLAMP	AL.ALLOY / GALV.STEEL	SCS4000A	SCS4000A	G00259017	120	2
11	P.A.ROADS	ALUMINIUM ALLOY	PAR/400/51	PAR/400/51	G00241008	-	2 SETS
10	CLEVIS EYE	GALVANIZED STEEL	CE1602	CE1602	G00209012	120	2
9	CLEVIS TWISTED	GALVANIZED STEEL	CTW1600	CTW1600	G00268001	240	1
8	TRIANGULAR YOKE PLATE	GALVANIZED STEEL	TYP2204	TYP2204	M00608141	240	2
7	H.H. SOCKET CLEVIS	GALVANIZED STEEL	HSC1602.1	HSC1602.1	G00223035	120	2
6	RING TYPE ARCING HORN	GALVANIZED STEEL	RTAH4205	RTAH4205	M00609110	-	2
5	RING TYPE ARCING HORN	GALVANIZED STEEL	RTAH4204	RTAH4204	M00609109	-	2
4	H.H BALL CLEVIS	GALVANIZED STEEL	HBC1600	HBC1600	G00260001	120	2
3	TRIANGULAR YOKE PLATE	GALVANIZED STEEL	TYP2203	TYP2203	M00608140	240	1
2	D-SHACKLE	GALVANIZED STEEL	DS4103	DS4103	G00211017	240	1
1	U BOLT	GALVANIZED STEEL	UB2201	UB2201	G00266010	240	1

PRODUCT CODE: DSI/T2/LJ/A

BILL OF MATERIAL



THIS DRAWING IS THE PROPERTY OF "TAG CORPORATION" AND SHOULD NOT BE COPIED OR REPRODUCED WITHOUT PROPER AUTHORIZATION.

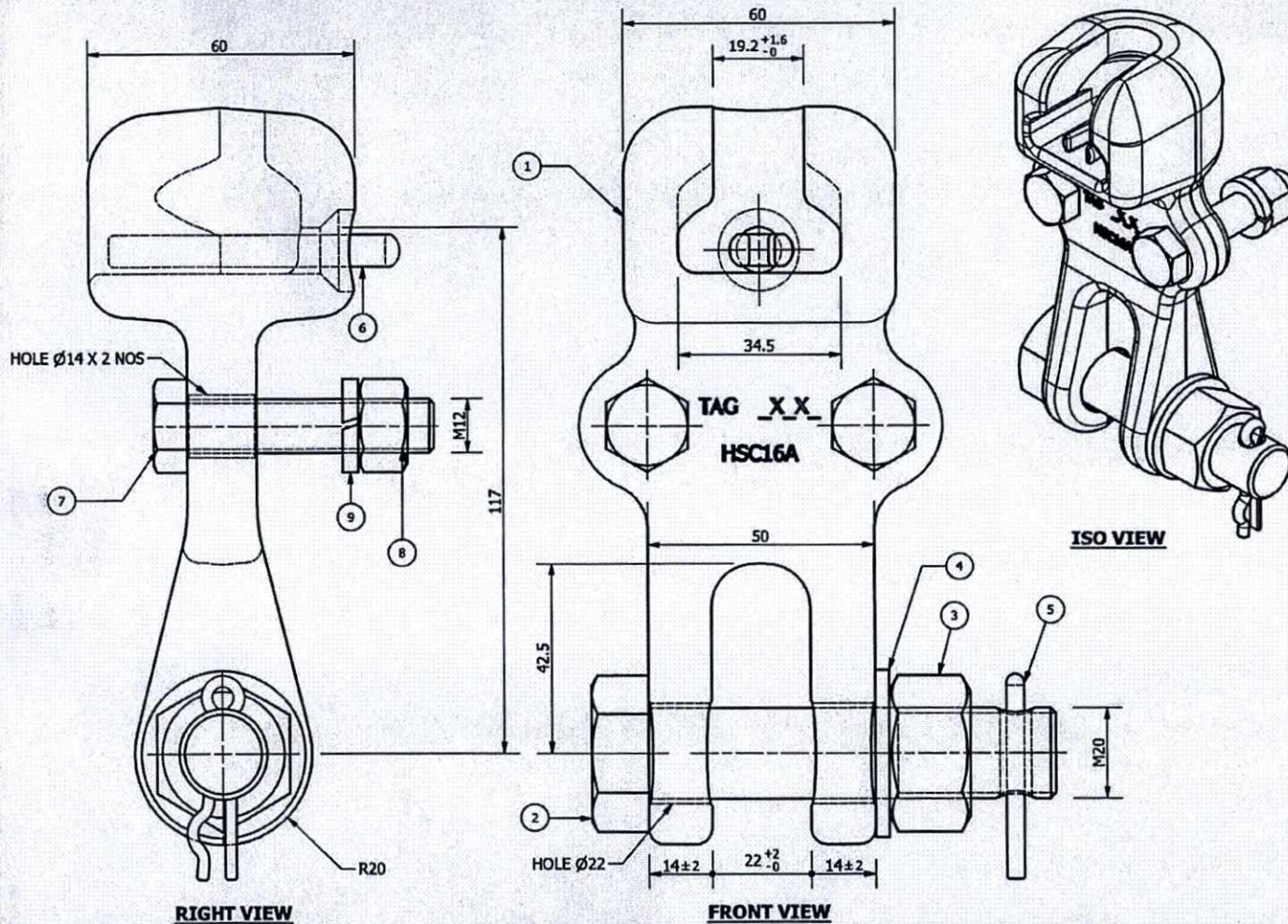

ITEM CODE G 0 0 2 2 3 0 3 5

**TECHNICAL DATA**

1. HOT DIP GALVANIZED AS PER ISO : 1461.
2. BREAKING STRENGTH - 120 KN
3. SOCKET DESIGNATION 16B mm AS PER IEC-120.
4. GENERAL TOLERANCE UNLESS OTHERWISE SPECIFIED IS ±3%.
5. TOTAL WEIGHT - 1.99 kg.
6. WEIGHT IS INDICATIVE ONLY.
7. ALL DIMENSIONS ARE IN MM.

Project Name	Package 03: Supply and transport of insulators and fittings, OPGW cable and accessories for 220kV Thai Binh - Tien Hai - Truc Ninh double circuit transmission line
P.O.Ref.No.	-
Purchaser	M/s. NPMB
Contractor	M/s.
Manufacturer	TAG CORPORATION, CHENNAI.

ITEM	DESCRIPTION	MATERIAL 2	ITEM CODE	UTS	QTY (NOS.)
9	SPRING WASHER (M12)	SPRING STEEL	B00211002	-	2
8	NUT (M12)	GALVANIZED STEEL (P.C.5.0)	-	-	2
7	BOLT (M12X55)-FT	GALVANIZED STEEL (P.C.5.6)	B00202065	-	2
6	R-CLIP (R/C001)	S.S (AISI - 304)	B00208001	-	1
5	SPLIT PIN(SP/001)	S.S (AISI - 304)	B00210001	-	1
4	FLAT WASHER (M20)	GALVANIZED STEEL	B00205005	-	1
3	NUT (M20)	GALVANIZED STEEL (P.C.5.0)	-	-	1
2	BOLT (M20X90)	GALVANIZED STEEL (P.C.5.6)	B00202036	-	1
1	H.H. SOCKET CLEVIS	GALVANIZED STEEL	M00507019	120	1

**BILL OF MATERIAL**

REV	DATE	DESCRIPTION	APP. BY
REVISION HISTORY			

ITEM NAME: **H.H. SOCKET CLEVIS**

DRG.NO: **HSC1602.1** DATE: 01.12.2016

DRAWN BY: P.P

CKD. BY: R.M

APP. BY: V.T.C

SCALE: 1:1

**TAG CORPORATION**  
CHROME PET, CHENNAI - 600 044  
EXPORT TAMILNADU, INDIA.